

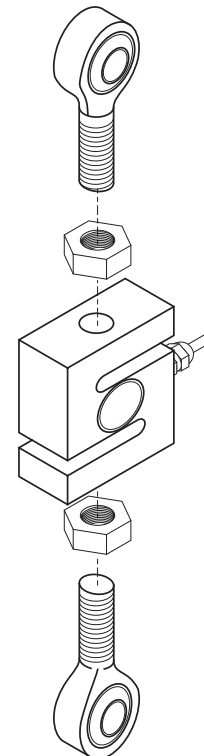

Applications

Mechanical mounting

The TA-I load cell is mounted using two rod end bearings, having opposing handed threads.



Presentation

General

The TA-I S-beam load cell consists of a stainless steel stress member which is totally sealed using welded stainless steel cups. It has been designed to be used in an aggressive industrial environment as, for example, that found in the chemical industry. It has been awarded a test certificate as conforming to R 60 for 1,000 e. Sealed and compact, the TA-I is available in 4 capacities : 500, 1,000, 2,000 and 5,000 kg.

Description

The TA-I load cell uses the principle of measuring the deformation of a stress member subjected to shear stress. It uses strain gauges connected in the form of a Wheatstone bridge to convert the force into an electrical signal.

Conformity

- Test certificate OIML nr R60-1991-GB-97.01

Wiring

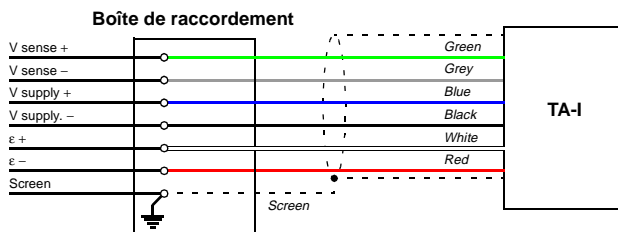

Electrical connection

The load cell delivers a low level analogue electrical signal. It is therefore necessary to take special precautions for the electrical cabling.

- Always connect the screen of the load cell in the junction box or in the indicator.
- Distance the load cell cable from anything that causes significant electromagnetic fields. Avoid routing a power cable with the measuring cable.
- Distance or protect the measuring elements from all sources of heat.

Physical characteristics

Models 500, 1,000 and 2,000 kg

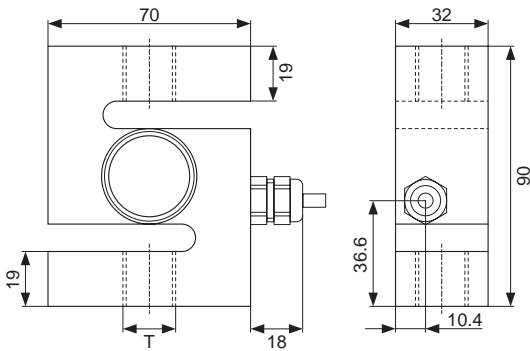

Models	500 kg	1 000 kg	2 000 kg
T (Ø x thread)	M12 x 1.75	M16 x 2.0	M16 x 2.0

Model 5,000 kg

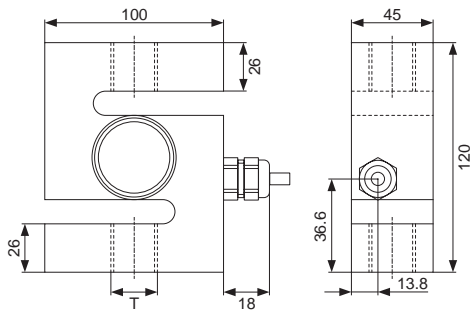

Models	5 000 kg
T (Ø x thread)	M24 x 2.0

Metrological characteristics

Models	500	1,000	2,000	5,000	
Rated load	E _{max} 500	1,000	2,000	5,000	kg
Minimum load	E _{min} 0	0	0	0	kg
Minimum interval	v min 80	160	320	800	g
Max. number of intervals	n max 1,000	1,000	1,000	1,000	

Mechanical characteristics

Models	500	1,000	2,000	5,000	
Safe load limit	750	1,500	3,000	7,500	kg
Destructive load	1,000	2,000	4,000	10,000	kg
Nominal load deflection	0.4	0.4	0.4	0.4	mm
Fixing* (T) - Ø x thread	M12 x 1.75	M16 x 2.0	M16 x 2.0	M24 x 2.0	

* Not supplied as standard

Electrical characteristics

- Maximum supply voltage AC or DC 12 V
- Input impedance 400 Ω ± 20 Ω
- Output impedance 350 Ω ± 3 Ω
- Insulation resistance > 1,000 MΩ
- Sensitivity 2 mV/V ± 0.1%
- Repeatability < 0.05%
- Temperature effect on sensitivity < 0.004 % / °C
- Temperature effect on zero < 0.007 % / °C
- Max. accuracy classification (Trade use) C1
- Screened cable, 6 core PVC covered
 - Length 5 m

Environmental

- Temperature range
 - Recommended - 10 °C / + 40 °C
 - Without degradation - 20 °C / + 60 °C
 - Storage - 25 °C / + 80 °C
- Sealing : Hermetic

Options

■ Rod end bearing fixings

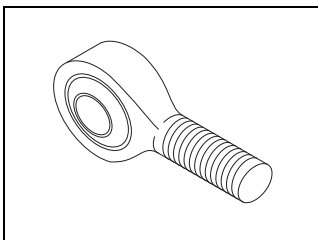

■ Junction box

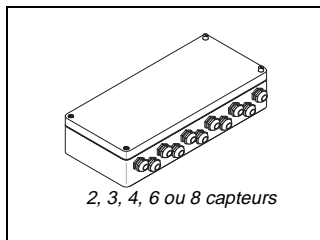

■ Cable extension box

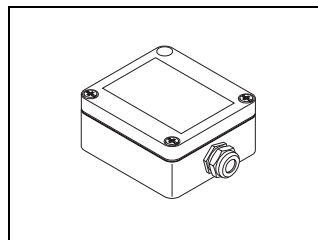

■ Others options & accessories

- Load cell cable 6 x 0,6 mm² special longer lengths (> 50 m).
- Load cell cable 6 x 0,22 mm² special SUB D 9 pins.
- Load cell cable 6 x 0,14 mm² special light industrial scales.

Votre spécialiste

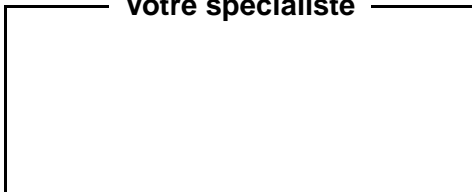

Illustrations non contractuelles. Precia-Molen se réserve le droit de modifier, à tout moment, les caractéristiques du matériel décrit dans cette brochure.

Siège social et usine

BP 106 - 07000 Privas - FRANCE
 Tél. 33 (0) 475 664 600
 Fax 33 (0) 475 658 330
 E-MAIL webmaster@preciamolen.com
 RCS : 386 620 165 RCS Aubenas

